

Mini5C+ Standard Package

www.FiberFox.co.kr

Mini 5C+

Core Alignment Splicer



- 1 MINI 5C+ Splicer
- 2 Cleaver Softcase
- 3 MINI 50GB+ Cleaver
- 4 Power Cord
- 5 USB Cable
- 6 AC Adapter
- 7 Car Cigar Cable
- 8 Cooling Tray
- 9 Spare Electrode
- 10 SOC Heater Block
- 11 SOC Holder
- 12 2 Battery Packs
- 13 Shoulder Strap
- 14 User Manual CD
- 15 Hand Carrying Case

Specifications

Splicing Method	Core Alignment. DCID (Digitalized Core Image Detecting) System
Average Loss	SM(0.02dB) / MM(0.01dB) / DS(0.04dB) / NZDS(0.04dB) / G.657(0.02dB)
Return Loss	>>60dB
Splice Time	Average SM/ SM Mode 8s, Quick mode 6s
Electrode Lifespan	>5,500 arcs
Applicable Fibers	SM(ITU-T G.652&T G.657)/MM(ITU-T G.651)/DS(ITU-T G.653)/NZDS(ITU-T G.655)
Illumination	LED emitting white light (1 PIECE)
Cleaved Length	Coating Diameter<0.25mm=5-16mm, Coating Diameter>0.25mm=8-16mm minimum
Coating Diameter	100-3,000um
Cladding Diameter	80-150um
Heating Programs	Factory installed mode : 4, User installable mode : 32
Heating Time	Typical 10s, micro Sleeve 60mm coating dia. 250um 5s
Protection Sleeve	40mm, 60mm, SOC Connector
Data Output	USB 2.0(Mini-B type) Connector for PC Communication
Splice Programs	Factory installed mode : 17, User installable mode : 128
Splice Memory	Up to 10,000 records and 2,000 Splice images
Battery	typical 300 Cycles(splice & Heat) / single battery <2 Batteries Standard> / OUT PUT 11.1V 5200mAh
Power Supply	AC 100-240V input or DC12.6V 1.8A
Monitor	Color 4.3" LCD monitor, with Touch Screen (Tempered Glass)
Cameras	2 CCD camera system
Magnification	XY style : 160 power, X/Y : 320 power
Fiber Display	X/Y or XY, single X.Y
Weight	1.42Kg(without battery)
Size	124mm x 123.2mm x 138mm
Wind Protection	The max wind speed 15m/s
Operating Environment	Elevation 0-5,000 meter, -10-50°C, 0-95%RH relative humidity
Storage Condition	Temperature -20 to 60°C, 0-95%RH relative humidity, battery -20-40°C
Pull Test	1.96-2.25N (standard)
Attenuation splicing	Rang : 0.1dB ~ 20dB(0.1dB step)



Core Alignment Splicer

1.42
kg

600
cycles

6
sec

0.02
dB

Characteristic



SOC Compatible

Fast Heating Time
10 sec

LED Injection



Mini 5C+

1.42kg
(Without Battery)
124 x 123 x 138 mm



Industry's First!
Two Batteries are Included
- 300 cycles (splicing & heating) with Two Batteries

Splice Time : 6 sec
Electrode Lifespan : 5,500 arcs

Full Touch Screen
- GUI Interface
- Tempered Glass

01

Technical Detail

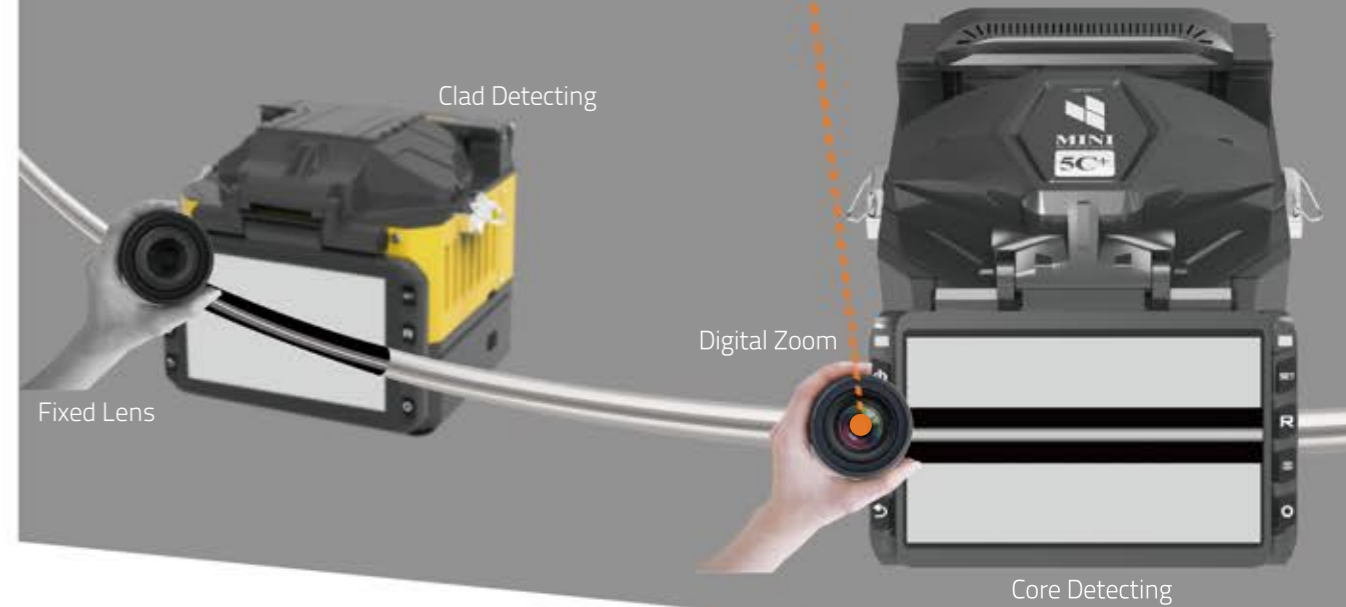
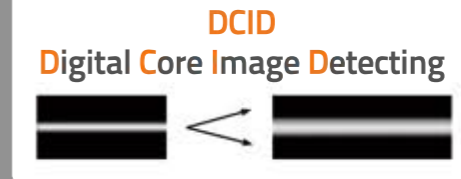

02

Durability

1meter



Anti-shock



Dustproof

Waterproof



03

Reliability

Perfect performance
under any environmental conditions



Temperature
-15~60°C



Relative humidity
0~95%



Elevation
0~5000meter



The max wind
speed 15m/s

Compliant with IEC Standard